

Instruction for Use

021519/01/09

Wind Transmitter „First Class“ Advanced

Classified according to IEC 61400-12-1 (2005-12)

4.3351.00.000

4.3351.10.000



Safety Instructions

- Before operating with or at the device/product, read through the operating instructions. This manual contains instructions which should be followed on mounting, start-up, and operation. A non-observance might cause:
 - failure of important functions
 - endangerment of persons by electrical or mechanical effect
 - damage to objects
- Mounting, electrical connection and wiring of the device/product must be carried out only by a qualified technician who is familiar with and observes the engineering regulations, provisions and standards applicable in each case.
- Repairs and maintenance may only be carried out by trained staff or **Adolf Thies GmbH & Co. KG**. Only components and spare parts supplied and/or recommended by **Adolf Thies GmbH & Co. KG** should be used for repairs.
- Electrical devices/products must be mounted and wired only in a voltage-free state.
- **Adolf Thies GmbH & Co KG** guarantees proper functioning of the device/products provided that no modifications have been made to the mechanics, electronics or software, and that the following points are observed:
- All information, warnings and instructions for use included in these operating instructions must be taken into account and observed as this is essential to ensure trouble-free operation and a safe condition of the measuring system / device / product.
- The device / product is designed for a specific application as described in these operating instructions.
- The device / product should be operated with the accessories and consumables supplied and/or recommended by **Adolf Thies GmbH & Co KG** .
- Recommendation: As it is possible that each measuring system / device / product may, under certain conditions, and in rare cases, may also output erroneous measuring values, it is recommended using redundant systems with plausibility checks for **security-relevant applications**.

Environment

- As a longstanding manufacturer of sensors Adolf Thies GmbH & Co KG is committed to the objectives of environmental protection and is therefore willing to take back all supplied products governed by the provisions of "*ElektroG*" (German Electrical and Electronic Equipment Act) and to perform environmentally compatible disposal and recycling. We are prepared to take back all Thies products concerned free of charge if returned to Thies by our customers carriage-paid.
- Make sure you retain packaging for storage or transport of products. Should packaging however no longer be required, please arrange for recycling as the packaging materials are designed to be recycled.



Documentation

- © Copyright **Adolf Thies GmbH & Co KG**, Göttingen / Germany
- Although these operating instruction has been drawn up with due care, **Adolf Thies GmbH & Co KG** can accept no liability whatsoever for any technical and typographical errors or omissions in this document that might remain.
- We can accept no liability whatsoever for any losses arising from the information contained in this document.
- Subject to modification in terms of content.
- The device / product should not be passed on without the/these operating instructions.

Contents

1	Models available.....	4
2	Application.....	4
3	Construction and Mode of Operation.....	4
4	Recommendation Side Selection / Standard Installation	5
5	Installation.....	5
5.1	Mechanical Mounting	6
5.2	Electrical Mounting.....	6
5.2.1	Cable.....	6
5.2.1.1	Cable Recommendation.....	6
5.2.2	Cable Shield	6
5.2.2.1	Connecting Recommendation for the Cable Shield.....	7
5.2.3	Plug and Cable Mounting	8
5.3	Connecting Diagram	9
6	Maintenance.....	10
7	Technical Data	11
8	Dimensional Drawing.....	12
9	Accessories (optional)	13
10	EC-Declaration of Conformity.....	14

Patent

Patent Nr.: EP 1 398 637

Patent Nr.: DE 103 27 632

Patent Nr.: EP 1 489 427

1 Models available

Order - No.	Meas. range	Output Frequency	Supply	Heating
4.3351.00.000	0.3...75 m/s	1082 Hz @ 50 m/s	3.3...48 V DC	24V AC/DC, 25 W
4.3351.10.000	0.3...75 m/s	1082 Hz @ 50 m/s	3.3...48 V DC	w/o heating

The following parts are included in delivery:

- 1 Instrument
- 1 Terminal plug
- 1 Instruction for Use

2 Application

The wind transmitter is designed for the acquisition of the horizontal component of the wind speed in the field of meteorology and environmental measuring technology, evaluation of location, and measurement of capacity characteristics of wind power systems.

Special characters are defined and optimised, dynamic behaviour also at high turbulence intensity, minimal over-speeding, and a low starting values.

The measuring value is available as digital signal at the output. It can be transmitted to display instruments, recording instruments, data loggers as well as to process control systems. For winter operation the instrument is optional equipped with an electronically regulated heating, which guarantees a smooth running of the ball bearings, and prevents the shaft and slot from icing-up.

3 Construction and Mode of Operation

A low-inertia cup star with 3 cups, made of carbon-fibre-reinforced plastic, is set into rotation by the wind. The rotation is scanned opto-electronically, and is converted into a square wave signal. The frequency of this signal is proportional to the number of rotations. Depending on the supply voltage, the output signal ranges between maximal output voltage and ground or a potential (life-zero^{*}), lifted by approx. 1.2 V. The supply of the electronics can be done by DC-voltage of 3.3 V up to 48 V at a very low current consumption. An AC- or DC-voltage of 24 V is intended for the separate supply of the optional heating. In all probability, the heating guarantees a trouble-free function of the Wind Transmitter First Class even under extreme meteorological icing-conditions.

The outer parts of the instrument are made of corrosion-resistant anodised aluminium. Highly effective labyrinth gaskets and O-rings protect the sensitive parts inside the instrument against humidity and dust. The instrument is mounted onto a mast tube; the electrical plug-connection is located in the transmitter shaft.

* Useable at a supply voltage > 5 V DC

4 Recommendation Side Selection / Standard Installation

In general, wind measuring instruments are supposed to record wind conditions over a large area. According to international regulations, the surface wind should be measured at a height of 10 m above even open terrain, in order to achieve comparable values. An open terrain is defined as terrain where the distance between the wind-measuring instrument and the next obstacle is at least ten times the height of this obstacle (acc. to VDI 3786 sheet 2 as well as Guide to Meteorological Instruments and Methods of Observation, Sixth Edition, WMO-No. 8). If this regulation cannot be fulfilled, the measuring instrument should be installed at a height at where the measurement values are not influenced by any local obstacles. In any case, the measuring instruments should be installed at a height of 6 to 10 m above the mean height of the buildings or trees in the vicinity. If it is necessary to install the instrument on a roof, it should be installed in the centre of the roof in order to avoid any preferential directions.

5 Installation

Attention:

Storing, mounting, and operation under weather conditions is permissible only in vertical position, as otherwise water can get into the instrument.

Remark:

When using fastening adapters (angle, traverses, etc) please take a possible effect to the measuring values by shading into consideration.

Caution:

The device may only be supplied with a power supply of the "Class 2, limited power".

5.1 Mechanical Mounting

The wind transmitter must be mounted on an instrument carrier, which is suited for the measurement. For dimensions of wind direction transmitter please refer to chapter 8.

Tools:

Hexagon socket wrench SW3
(Allen key)

Procedure:

1. Push cable/ plug connector of the wind transmitter through the borehole of the mast, tube, arm etc.
2. Put wind transmitter on mast, tube, arm etc.
3. Safeguard the wind transmitter by two M6-Allen head screws



Remark:

Suitable instrument carriers are masts, tubes, traverses, arms, adapters, adapters of POM for isolated mounting, which correspond to the mounting dimensions of the wind transmitter, and to the static requirements.

The inner diameter of the instrument carrier should be ≥ 20 mm based on plug- and cable feed-through.

5.2 Electrical Mounting

5.2.1 Cable

Solder a shielded cable with diameter 7-8 mm and a core cross-section of 0.5...0.75 mm² to the enclosed coupling socket.

- The number of necessary wires is given in the connection diagram (chapter 5.3).

5.2.1.1 Cable Recommendation

No. of wires/ diameter / type / cable diameter
CABLE 4X0.5mm ² LI9YC11Y BLACK, UV- resistant, Ø 6 mm
CABLE 8x0.5mm ² LIYCY BLACK, UV- resistant, Ø 7.6 mm

5.2.2 Cable Shield

The connection of the cable shield between sensor and data acquisition device should be selected in way, that in case of over-voltages no equalizing currents will flow that might destroy the electronic components.

The connection of the cable shield should depend on the selected isolated, or respectively, non-isolated mounting of the sensors.

5.2.2.1 Connecting Recommendation for the Cable Shield

	Sensor Carrier	Sensor	Shielding / Ground	Lightning Protection
1.	Metallic measurement mast, grounded	Isolated mounting at the measuring mast (e.g. by non-metallic brackets, holder etc. or by metallic brackets, holder etc. with isolated plastic adaptors)	Apply the cable shield between sensor and data acquisition device (e.g. datalogger) both-sided. Ground data acquisition device.	Mount metallic lightning protection rod on the mast. Alternatively: Install separate lightning protection rod beside the measurement mast.
2.	Metallic measurement mast, grounded	Non-isolated mounting at the measurement mast (e.g. by metallic brackets, holders etc.)	Apply cable shield between sensor and data acquisition device (e.g. datalogger) only one-sided at the acquisition device. Ground data acquisition device.	Mount metallic lightning protection rod on the mast in isolated condition , and ground lightning protection rod. Alternatively: Install separate lightning protection rod beside the measurement mast.
3.	Metallic measurement mast, not grounded (mounted in isolated condition, e.g. on the attic)	Non-isolated mounting at the measurement mast (e.g. by metallic brackets, holders etc.)	Apply the cable shield between sensor and data acquisition device (e.g. datalogger) both-sided. Ground data acquisition device.	Mount metallic lightning protection rod on the mast in isolated condition , and ground lightning protection rod. Alternatively: Install separate lightning protection rod beside the measurement mast.
4.	Non-metallic measuring mast (=isolated)	Mounting at the measurement mast (e.g. by metallic brackets, holders etc.)	Apply the cable shield between sensor and data acquisition device (e.g. datalogger) both-sided. Ground data acquisition device.	Mount metallic lightning protection rod on the mast, and ground lightning protection rod. Alternatively: Install separate lightning protection rod beside the measurement mast.

5.2.3 Plug and Cable Mounting

Coupling socket, Type: Binder, Serial 423, EMC with cable clamp

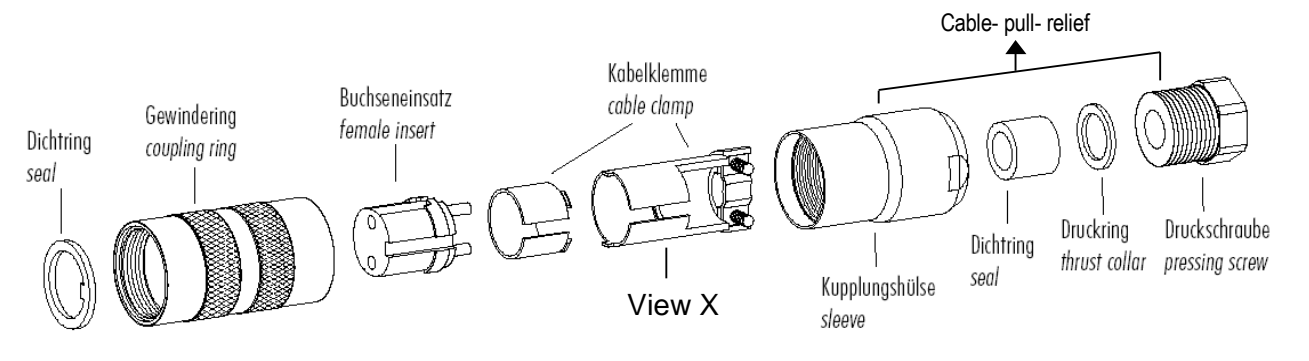

Cable connection: **with** cable shield

1. Stringing parts on cable acc. to plan given above.
2. Stripping cable sheath 20 mm
Cutting uncovered shield 15 mm
Stripping wire 5mm.

Cable mounting 1

Putting shrink hose or insulating tape between wire and shield.

Cable mounting 2

If cable diameter permits, put the shield backward on the cable sheath.

3. Soldering wire to the insert, positioning shield in cable clamp.
4. Screwing-on cable clamp.
5. Assembling remaining parts acc. to upper plan.
6. Tightening pull-relief of cable by screw-wrench (SW16 und 17).

Cable mounting 1

View X

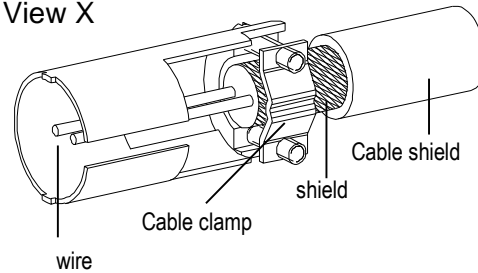

Cable mounting 2

View X

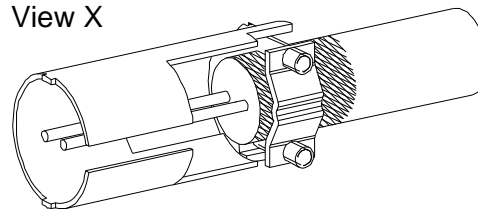

Cable connection: **without** cable shield

1. Stringing parts on cable acc. to plan given above.
2. Stripping cable sheath 20 mm
3. Cutting uncovered shield 20 mm
4. Stripping wire 5mm.
5. Soldering wire to the insert.
6. Positioning shield in cable clamp.
7. Screwing-on cable clamp.
8. Assembling remaining parts acc. to upper plan.
9. Tightening pull-relief of cable by screw-wrench (SW16 und 17).

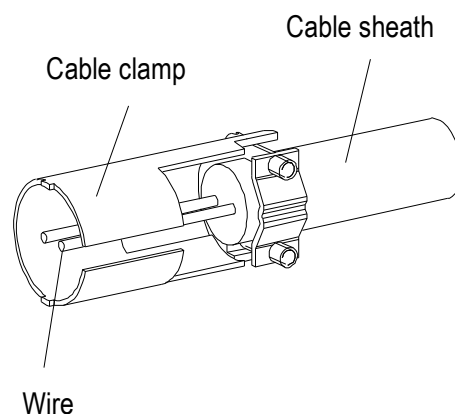

5.3 Connecting Diagram

Connection diagram acc. to chapter 5.2.2.1 no.1, 3 and 4:

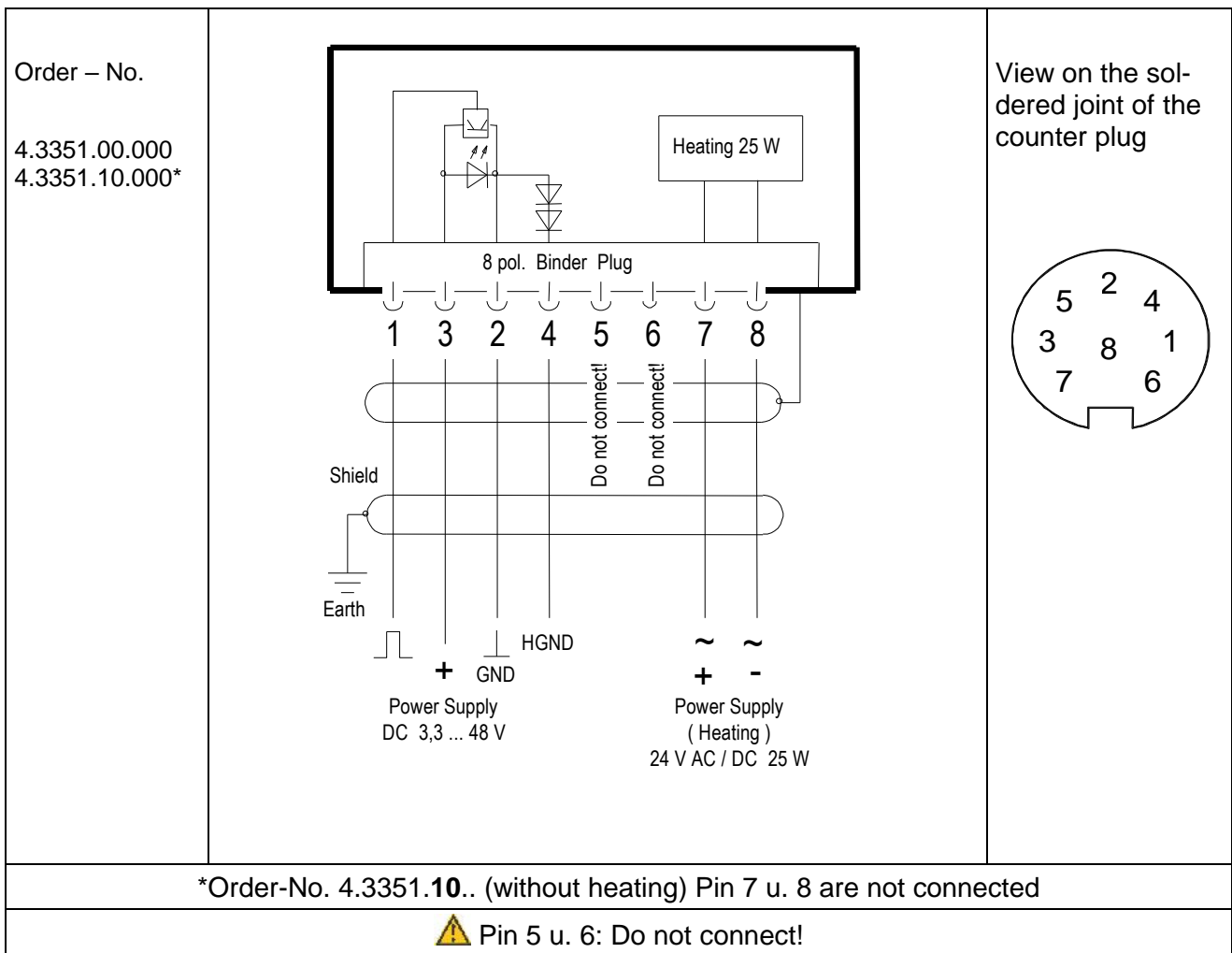

Pin	Name	Function
1	SIG	Signal (rectangle)
2	GND	Ground
3	+Us	Supply 3.3 V...48 V DC
4	HGND	Ground at life-zero signal
5		Do not connect!
6		Do not connect!
7	HZG	Heating supply: voltage: 24 V AC/DC power: 25 W
8	HZG	
<p>*Order-No. 4.3351.10.. (without heating) PIN 7 u. 8 are not connected</p>		

Remark:
The “live-zero” – operating (HGND) can be used only from a supply > 5 V DC.

6 Maintenance

If properly installed, the instrument requires no maintenance. Heavy pollution can lead to blockage of the slot between the rotating and the stable parts of the transmitter. Thus it is advisable to remove the accumulated dirt from the instrument.

Cleaning

For the cleaning of the device should use a damp cloth without chemical cleaning agents are used.

Certain symptoms of wear and tear can appear on the ball bearings after years of use. These symptoms are expressed in a lowered sensitivity of response, standstill or run-noises of the ball bearings. In case that such disturbances might occur we recommend to return the instrument - in original package - to the factory for maintenance work.

Remark:

For transport of instrument please use original packing.

7 Technical Data

Characteristic	Description
Measuring range	0.3...75 m/s
Accuracy	0.3...50 m/s 1% of meas. value or < 0.2 m/s
Survival speed	80 m/s (min. 30 minutes)
Permissible Ambient conditions	- 50...+ 80°C, all occurring situations of relative humidity (incl. dew moistening)
Output signal	<p>Form rectangle, edge steepness < 1µsec</p> <p>Frequency 1082 Hz @ 50 m/s</p> <p>Amplitude is supply voltage, max. 15 V</p> <p>Push-Pull Output output resistance: typical 100Ω ≥ 10V, 130Ω @ 5V, 230Ω @ 3.3V Constant power limiting on typical 25mA</p> <p>Open Drain Output Drain resistance typical 50Ω, Pull-Up-voltage max. 30V Constant power limiting on typical 50mA,</p> <p>Load R ≥ 1 kΩ C ≤ 200 nF (corresp. to length typical cable < 1km)</p>
Linearity	Correlation factor r between frequency and wind speed y=0.0462* f +0.21 typical r > 0.999 99 (4...20 m/s)
Starting velocity	< 0.3 m/s
Resolution	0.05 m wind run
Distance constant	< 3 m (acc. to ASTM D 5096 – 96) 3 m acc. to ISO 17713-1
Turbulent flow	Deviation Δv turbulent compared with stationary horizontal flow -0.5% < Δv < +2% Frequency < 2 Hz
Classification	According to IEC 61400-12-1 (2005-12) Class A classification index A 0.9 Class B classification index B 3.0 Class S classification index S 0.5
Wind load	Approx.. 100 N @ 75 m/s
Heating	Surface temperature of housing neck > 0°C at 20 m/s up to -10°C air temperature, at 10 m/s up to -20°C using the THIES icing standard 012002 on the housing neck. Heating regulated by temperature sensor
Electrical supply for opto-electronic scanning	Voltage: 3.3...48 V DC (galvanic isolation from housing) Current: 130µA typ. 150µA max. @ 3,3V bis 15,0V (w/o external load) 180µA typ. 200µA max. @ 15V bis 48V (w/o external load)
Electrical supply for heating	Voltage: 24 V AC/DC, 54...65Hz (galvanic isolation from housing) Idling voltage: max. 30 V AC, max. 48 V DC Capacity: 25 W

Connection	8-pole plug-connection for shielded cable in the shaft (see connecting diagram)
Mounting	Mounting on mast R 1", for ex. DIN 2441 1½ " with separate adaptor (option)
Dimensions	See dimension diagram
Weight	approx. 0.5 kg
Protection	IP 55 (DIN 40050)

8 Dimensional Drawing

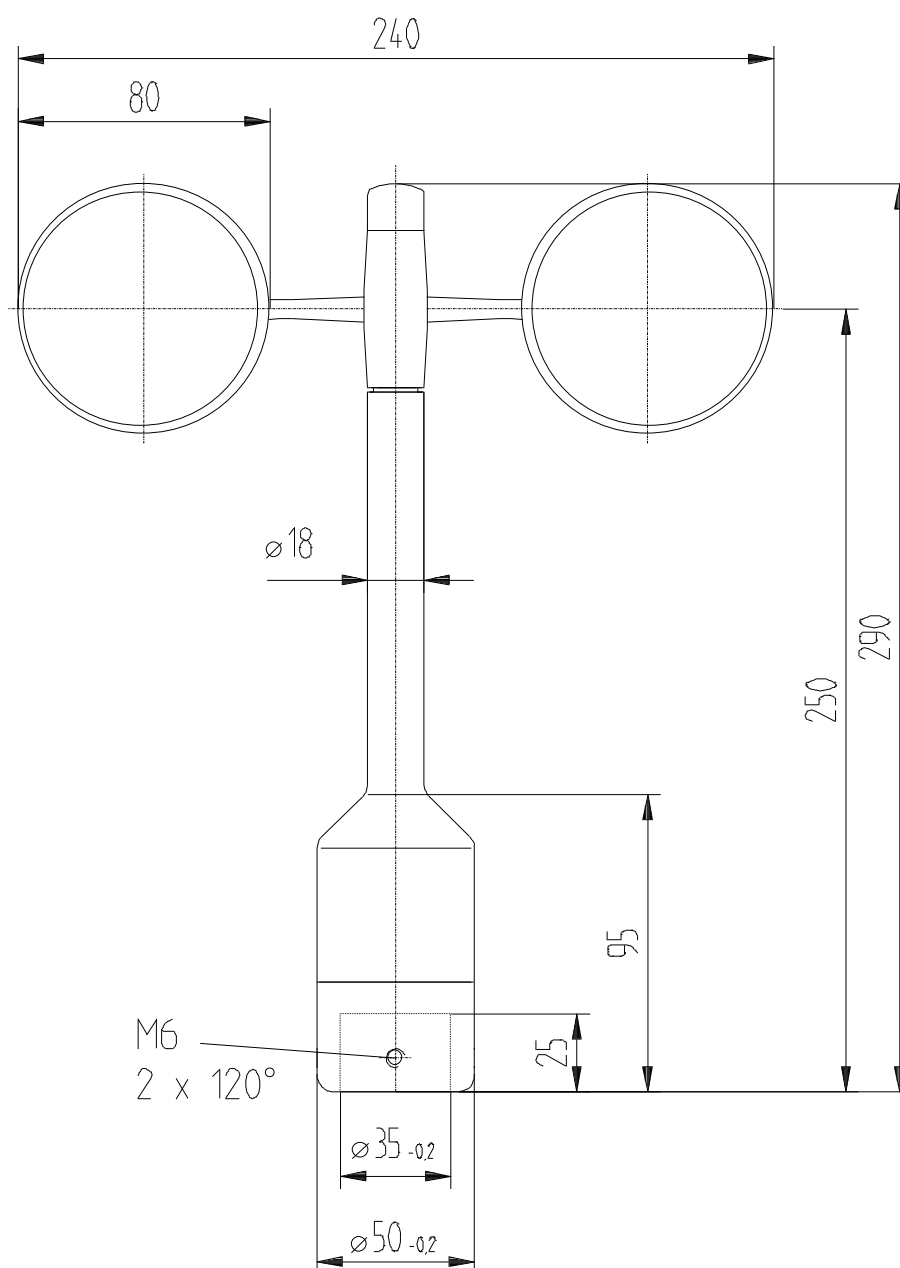

9 Accessories (optional)

<p>Traverse 0.6 m</p> <p>For mounting the wind speed and wind direction transmitter jointly onto a mast.</p>	4.3174.00.000	<p>Horizontal sensor distance: 0.6 m</p> <p>Vertical sensor distance: 0.2 m</p> <p>Mast receptacle: 48 - 50 mm</p> <p>Material: Aluminum, anodised</p> <p>Dimensions: tube Ø 34x4mm, 668 mm long, 756 mm high</p>
<p>Hanger</p> <p>–FIRST CLASS- 1m</p> <p>For the lateral mounting of a wind speed and wind direction transmitter onto a mast tube.</p>	4.3184.01.000	<p>Sensor distance to mast: 1 m</p> <p>Mast clamp: 40 – 80 mm</p> <p>Tube diameter: 34 mm</p> <p>Material: Aluminum</p>
<p>Lightning rod</p> <p>For mounting the a/m traverse or hanger.</p>	4.3100.98.000	<p>Dimension: Ø 12 mm, 500 mm long, 1050 mm high</p> <p>Material: Aluminum</p>
<p>Adaptor</p> <p>For isolated mounting of each wind transmitter and wind direction transmitter on the traverse (4.3174.0.000).</p>	509077	<p>Dimension: A:Ø 34 mm, outside 25 mm high B:Ø 35 mm, inside 45 mm high</p> <p>Material: POM</p>

Please contact us for other accessories such as cables, power supply units, masts, as well as for additional mast- or system-constructions.

Example: Wind transmitter with traverse 4.3174.00.000 and lightning rod 4.3100.98.000.



10 EC-Declaration of Conformity

Document-No.: 001574

Month: 01 Year: 09

Manufacturer: **ADOLF THIES GmbH & Co. KG**

Hauptstr. 76
D-37083 Göttingen
Tel.: (0551) 79001-0
Fax: (0551) 79001-65
email: Info@ThiesClima.com

Description of Product: **Windsensor FIRST CLASS**

Article No.	4.3350.00.000	4.3350.10.000	
	4.3350.00.140	4.3350.00.141	4.3350.00.161
	4.3350.10.140	4.3350.10.141	4.3350.10.161
	4.3351.00.000	4.3351.10.000	
	4.3351.00.140	4.3351.00.141	4.3351.00.161
	4.3351.10.140	4.3351.10.141	4.3351.10.161

specified technical data in the document: **021309/07/06; 021435/01/07; 021518/01/09; 021548/01/09**

The indicated products correspond to the essential requirement of the following European Directives and Regulations:

- 2004/108/EC DIRECTIVE 2004/108/EC OF THE EUROPEAN PARLIAMENT AND OF THE COUNCIL of 15 December 2004 on the approximation of the laws of the Member States relating to electromagnetic compatibility and repealing Directive 89/336/EEC
- 2006/95/EC DIRECTIVE 2006/95/EC OF THE EUROPEAN PARLIAMENT AND OF THE COUNCIL of 12 December 2006 on the harmonisation of the laws of Member States relating to electrical equipment designed for use within certain voltage limits
- 552/2004/EC Regulation (EC) No 552/2004 of the European Parliament and the Council of 10 March 2004 on the interoperability of the European Air Traffic Management network (the interoperability Regulation)

The indicated products comply with the regulations of the directives. This is proved by the compliance with the following standards:

Reference number	Specification
IEC 61000-6-2: 2005	Electromagnetic compatibility Immunity for industrial environment
IEC 61000-6-3: 2006	Electromagnetic compatibility Emission standard for residential, commercial and light industrial environments
IEC 61010-1: 2001	Safety requirements for electrical equipment for measurement, control and laboratory use. Part 1: General requirement

Place: Göttingen

Date: 22.01.2009

Legally binding signature:

issuer:

.....
Wolfgang Behrens, General Manager

.....
Joachim Beinhorn, Development Manager

This declaration certifies the compliance with the mentioned directives, however does not include any warranty of characteristics. Please pay attention to the security advises of the provided instructions for use.



Official BeNeLux distributor: www.catec.nl



- Alterations reserved -